



PIATTAFORMA PER LAVORO AEREO AUTOCARRATA

TRUCK-MOUNTED AERIAL LIFT WORK PLATFORM

HUBARBEITSBÜHNE AUF LKW



PT 160

isoli@isoli.com | www.isoli.com

Marc THISSEN
0495 123 764
www.vibam.com
marc.thissen@vibam.com



DIMENSIONI / OVERALL DIMENSION / GESAMTABMESSUNGEN [mm]



DIAGRAMMA DI LAVORO / WORKING DIAGRAM / ARBEITSDIAGRAMM [m]



CARATTERISTICHE TECNICHE / TECHNICAL FEATURES / TECHNISCHE EIGENSCHAFTEN

	Altezza max. di lavoro Max. working height Max. Arbeitshöhe	16 m
	Sbraccio max. di lavoro Max. working boom extension Max. Reichweite	8,9 m
	Portata Capacity Traglast	250 Kg
	N. operatori N. operators Anzahl Personen	2
	Altezza piano calpestio Walk-on surface height Korbodenhöhe	14 m
	Rotazione sovrastruttura Upperstructure rotation Drehung Oberwagen	400°
	Cesta Basket Arbeitskorb	Alluminio 1400 x 710 x 1100 mm Aluminium 1400 x 710 x 1100 mm Alluminium 1400 x 710 x 1100 mm
	Rotazione cesta Basket rotation Korb-schwengung	+/- 90°
	Stabilizzatori Outriggers Abstützungen	H+H / A+A
	Comandi Controls Steuerungen	Elettroidraulici Electro-hydraulic Elektrohydraulisch

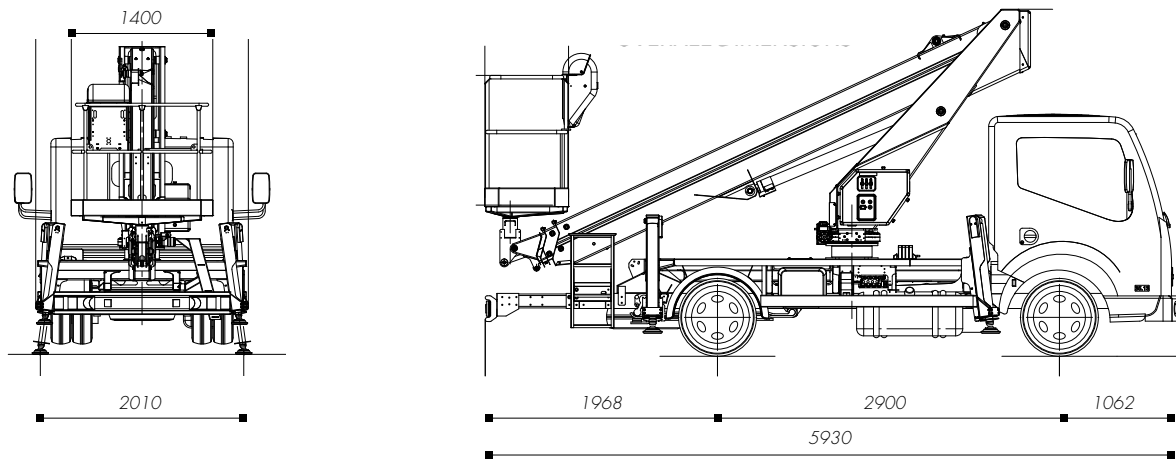
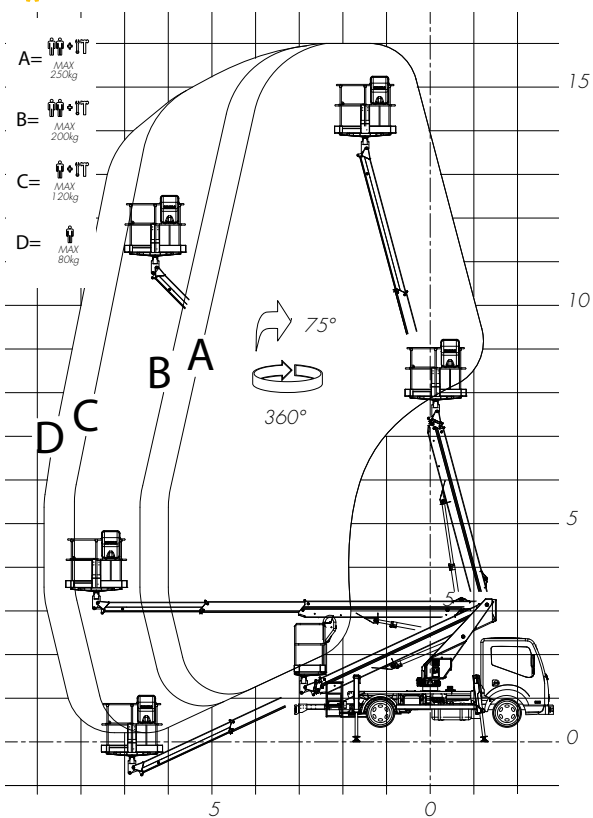
Marc THISSEN
0495 123 764
www.vibam.com
marc.thissen@vibam.com